

## High Efficiency, Constant Current 20V White-LEDs Driver

### Feature

- Operating Voltage: 2.5V to 20V.
- High Operating Frequency: 1MHz
- High Output Voltage: Up to 20V(Typ.)
- Digital Dimming Control.
- Built-in Cycle-by Cycle Current-Limiting.
- Built-in Soft-Start Function.
- 0.2V Low Reference Voltage
- Thermal Overload Protection
- Thin 8-Lead 2x2 TDFN Packages

### Application

- GPS Navigation System
- Compact Back Light Module
- Constant Current Source
- LED Module

### Description

The G2619 step-up converter drives white LEDs with a constant current to provide backlight in cell phones, PDAs, and other hand-held devices. It features allowing series connection of the white LEDs so that the LED currents are identical for uniform brightness. An enable input can be pulsed repeatedly to adjust LED's brightness. The fast 1.0 MHz current-mode PWM control allows for smaller capacitor and inductor. Fault condition protection uses cycle-by-cycle current limiting to sense maximum inductor current, thermal protection and over-voltage protection. Also included soft-start eliminates inrush current during start-up. The low reference voltage minimized the power loss across the current-setting resistor.

The G2619 is available in TDFN2x2-8 packages.

### Ordering Information

| ORDER NUMBER | MARKING | TEMP. RANGE   | PACKAGE (Green) |
|--------------|---------|---------------|-----------------|
| G2619RC1U    | 2619    | -40°C to 85°C | TDFN2x2-8       |

Note: RC: TDFN2X2-8  
 1 : Bonding Code  
 U: Tape & Reel

### Pin Configuration

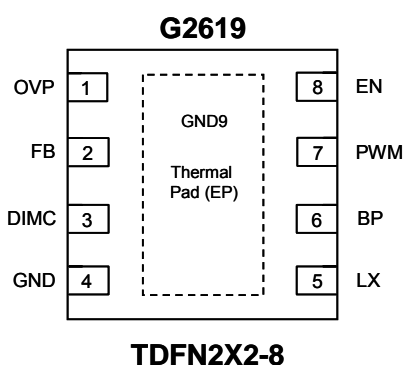

### Typical Application Circuit

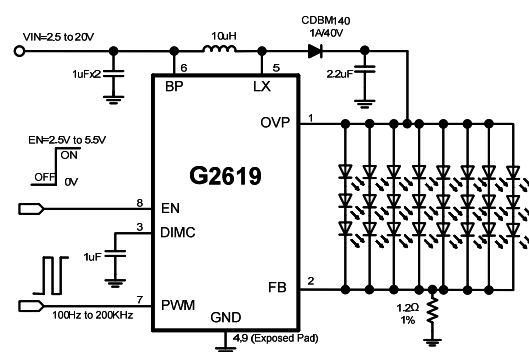

※ Use the tantalum capacitor to eliminate inductor noise on output terminal when you want to control dimming function.