

Dual-Low On-Resistance Load Switch with Controlled Turn-On

Features

- Integrated Dual Channel Load Switch
- Input Voltage Range: 0.8-V to 5.5V
- Dual Ultra-low ON-Resistance (10mΩ)
- 6A Continuous Switch Current per channel
- Low Threshold Control Inputs
- Adjustable Slew-rate Control
- Quick Output Discharge Transistor
- 10 Pin AQFN Package

Applications

- Notebooks / Netbooks
- Tablet PCs
- Consumer Electronics
- Set-Top-Boxes
- Industrial Systems
- Telecom Systems

General Description

The G5010 is dual N-channel MOSFET power switch designed for high-sideload-switching applications, and the device has a typical $R_{DS(ON)}$ of 10m and the output current is limited to 6A. Each switch is independently controlled by an on/off input (EN1, EN2), which is capable of interfacing directly with low-voltage GPIO control signals.

In the G5010, a 320Ω on-chip load resistor is added for quick output discharge (QOD) when the switch is turned off. The rise time of the device is internally controlled in order to avoid in-rush current and can be adjusted using a ceramic capacitor on the CTx pins.

The G5010 is available in 10 pin AQFN package.

Ordering Information

ORDER NUMBER	MARKING	TEMP. RANGE	PACKAGE (Green)
G5010AC1U	5010	-40°C to 85°C	AQFN2X2-10

Note: AC: AQFN2X2-10
 1: Bonding Code
 U: Tape & Reel

Pin Configuration

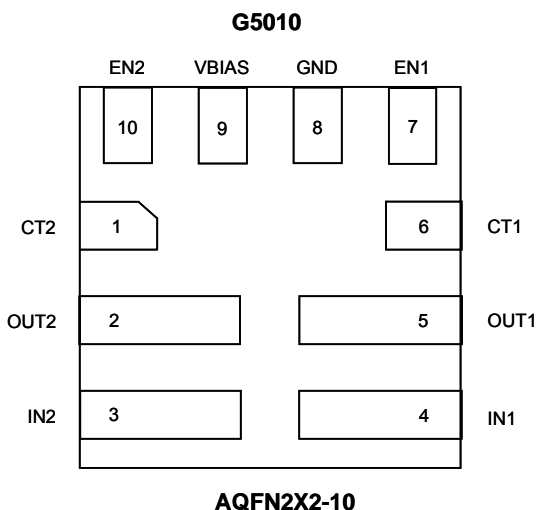

Typical Application Circuit

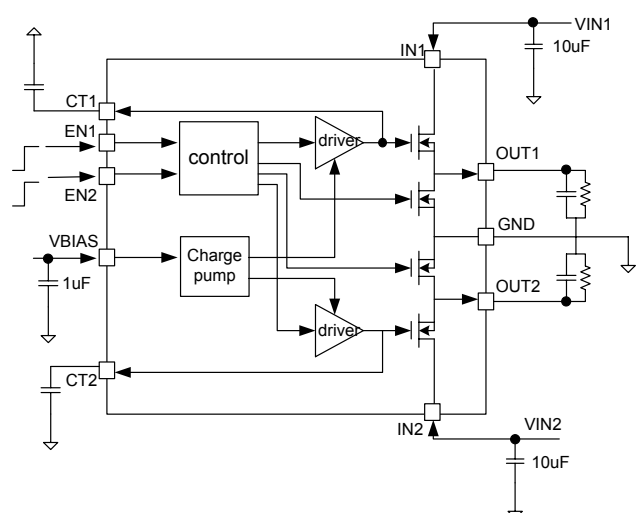

* AQFN2X2-10 Flip-Chip package thermal guide:

- 1) All of leads can help power dissipation.
 - 2) Keep all of PCB trace(near leads) width as wide as possible.
- Please refer to PCB layout considerations for example.