



Three Remote Temperature Sensors and One Fan Controllers with SMBus Serial Interface and System Reset Circuit

Features

- Measures Three Remote Temperatures
- Adjustable Offset for Each Sensor via SMBus
- Support Single-Core, Dual-Core and Quad-Core CPU Application
- Accuracy: $\pm 1^{\circ}\text{C}$ ($+60^{\circ}\text{C}$ to $+100^{\circ}\text{C}$)
 $\pm 3^{\circ}\text{C}$ (-10°C to $+120^{\circ}\text{C}$)
- +4.5V to +5.5V Supply Range
- Programmable Hardware Thermal Shutdown for Sensor 3 and Programmable Software Thermal Shutdown for Sensor 1, 2.
- SMBus 2-Wire Serial Interface With Writing Protection Function.
- Alert Signal for Diode Fault, Fan Fail, and Fan Out of Control
- Supports SMBus Alert Response
- Fan Drivers Using Linear Control Algorithm with Built-in MOSFET
- Closed Loop Speed Control and programmable 8 Bits Open Loop Voltage Control for Fan1
- Wide speed control range for Fan1, Accuracy within 2%, when SET_CNT1 > 50
- Internal Current- limit and Over-temperature Protection for the Fan
- Reset Function Precision Monitoring of 5V Power-Supply Voltage
- Measure Thermal Diode with Transistor Model
- Support 45nm, 65nm and 90nm CPU thermal diode
- Internal Clock 32768Hz, Accuracy $\pm 3\%$ from 25°C to 80°C at 5V VCC
- Programmable to Use External Clock
- TQFN4X4-24 Package

Applications

- Desktop and Notebook
- Central Office Computers
- Telecom Equipment
- Smart Battery Packs
- Industrial Controls
- LAN Servers

General Description

The G7923 contains 3 precise digital thermometers, one fan controllers, hardware and software thermal shutdown, and a system-reset circuit.

The thermometers report the temperature of 3 remote sensors. The remote sensors are diode-connected transistors typically a low-cost, easily mounted 2N3904 NPN type or the diode built-in in CPU. Remote accuracy is $\pm 1^{\circ}\text{C}$ for multiple transistor manufacturer. The G7923 also support offset adjust function via SMBus to fix the error due to different CPU diode or parasitic resistors.

The 2-wire serial interface accepts standard System Management Bus (SMBus™) Write Byte, Read Byte, Send Byte, and Receive Byte commands. The SMBus address is 7ah for write and 7bh for read, and supports writing protection function by command 20h to prevent error behavior of μP .

G7923 contains one fan controllers. FAN1 controller performs closed-loop and open-loop control. G7923 determines the current fan speed based on the FG inputs and an externally supplied 32.768kHz clock. The driving ability of FAN1 is 500mA. G7923 also provide ALERT for fan fail and out of control event.

The G7923 provides hardware and software thermal shutdown. The hardware thermal shutdown is for the sensor 3. The trigger point is set by external resistors. The trigger points of software thermal shutdown are set via SMBus. If thermal shutdown event occurs, $\overline{\text{THERM}}$ pin outputs low.

The G7923 contains a microprocessor (μP) supervisory circuit used to monitor the power supplies in μP and digital systems. Reset threshold is set to 4.38V typical.

Ordering Information

ORDER NUMBER	MARKING	TEMP. RANGE	PACKAGE (Green)
G7923R51U	7923	-55°C to $+125^{\circ}\text{C}$	TQFN4X4-24

Note: R5: TQFN4X4-24

1: Bonding Code

U: Tape & Reel

Pin Configuration

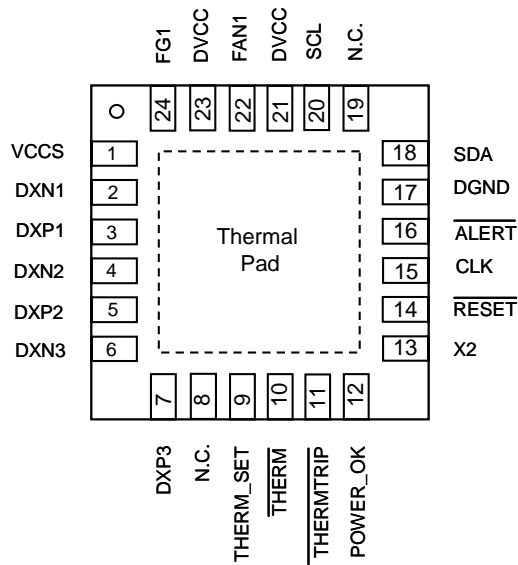

G7923 TQFN4X4-24

Note: Recommend connecting the Thermal Pad to the Ground for excellent power dissipation.

SMBus™ is a trademark of Intel Corp.