

1MHz, All-Ceramic, 2A PWM Buck DC/DC Converter

Features

- Ceramic Input and Output Capacitors
- Efficiency Up to 94%
- Guaranteed 2A Output Current
- Operate from 2.5V to 6V Supply
- Adjustable Output from 0.8V to V_{IN}
- Internal Soft-Start
- Short-Circuit and Thermal-Overload Protection
- Input Over Voltage Protection
- RoHS Compliant

Applications

- ASIC/DSP/ μ P/FPGA Core and I/O Voltages
- Set-Top Boxes
- Cellular Base Stations
- Networking and Telecommunications

General Description

The AT1526 high-efficiency, DC/DC buck converter delivers up to 2A of output current. The device operates from an input voltage of 2.5V to 6V and provides an output voltage from 0.8V to V_{IN} , making the AT1526 ideal for on-board post-regulation applications.

The AT1526 operate at a fixed frequency of 1MHz with an efficiency of up to 94%. The high operating frequency minimizes the size of external components. Internal soft-start control circuitry reduces inrush current. Short-circuit and thermal-overload protections improve design reliability.

The AT1526 are available in a space-saving 8-pin SO package.

Ordering Information

ORDER NUMBER	MARKING	TEMP. RANGE	PACKAGE (Green)
AT1526P11U	A1526	-40°C to +85°C	SOP-8

Note: P1:SOP-8
 1: Bonding Code
 U: Tape & Reel

Pin Configuration

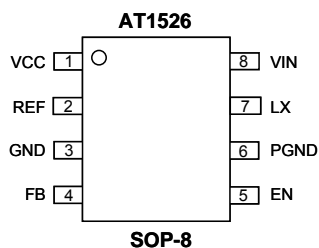

Typical Application Circuit

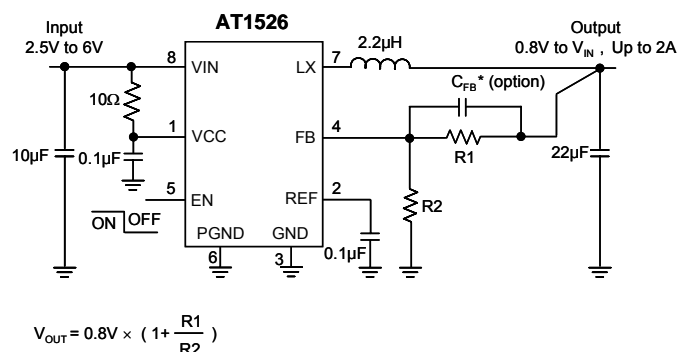

1MHz, All-Ceramic, 3A PWM Buck DC/DC Converter

Features

- Ceramic Input and Output Capacitors
- Efficiency Up to 94%
- Operate from 2.5V to 6V supply
- Adjustable Output from 0.8V to V_{IN}
- Internal Soft-Start
- Short-Circuit and Thermal-Overload Protection
- Input Over Voltage Protection
- RoHS Compliant

Applications

- ASIC/DSP/ μ P/FPGA Core and I/O Voltages
- Set-Top Boxes
- Cellular Base Stations
- Networking and Telecommunications

General Description

The AT1527 high-efficiency, DC/DC buck converter delivers up to 3A of output current. The device operates from an input voltage of 2.5V to 6V and provides an output voltage from 0.8V to V_{IN} , making the AT1527 ideal for on-board post-regulation applications.

The AT1527 operate at a fixed frequency of 1MHz with an efficiency of up to 94%. The high operating frequency minimizes the size of external components. Internal soft-start control circuitry reduces inrush current. Short-circuit and thermal-overload protections improve design reliability.

The AT1527 are available in a space-saving 8-pin SO package.

Ordering Information

ORDER NUMBER	MARKING	TEMP. RANGE	PACKAGE (Green)
AT1527F11U	A1527	-40°C to +85°C	SOP-8 (FD)

Note: F1:SOP-8 (FD)
 1: Bonding Code
 U: Tape & Reel

Pin Configuration

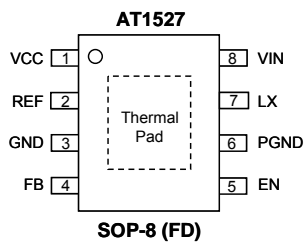

Note: Recommend connecting the Thermal Pad to the Ground for excellent power dissipation.

Typical Application Circuit

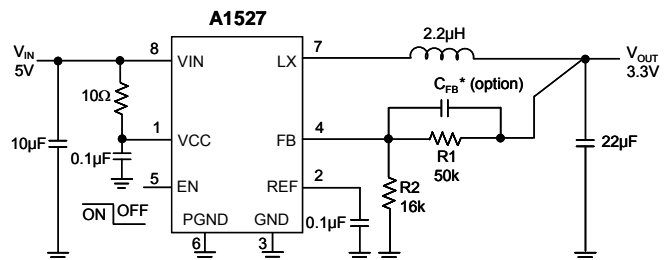

$$V_{OUT} = 0.8V \times \left(1 + \frac{R1}{R2}\right)$$